



Business: 563-238-2500
E-mail: pschwick@FirstChoiceRealty1.com

Toll Free: 888-531-1502
www.FirstChoiceRealty1.com

Home: 641-394-2637 Cell: 319-240-6879
www.iowarealtors.com



STYLE:	2 STORY	SMOKE ALARMS:	YES
BUILT IN:	1900	ANTENNA:	YES
SQ. FT.:	SEE DIAGRAM	CABLE:	AVAILABLE
TAXES:	\$522.00	INSULATION:	UNKNOWN
POSSESSION:	ASAP	PATIO:	NO
TERMS:	CASH	PORCHES:	1-EP & 1 OP
LOT SIZE:	66' X 129'	DECK:	NO
HOME FACES:	EAST	ATTIC:	NO
SCHOOL DIST.:	NEW HAMPTON	FIREPLACE:	NO
PHONE SERVICE:	NEW HAMPTON	AIR CON.:	NO
CONSTRUCTION:	WOOD FRAME	BUDGET:	UNKNOWN
ROOF TYPE:	GABLE/ASPHALT	W. SOFTENER:	YES
INTERIOR WALLS:	PLASTER	W. HEATER:	GAS
SIDING:	ALUMINUM	WATER:	CITY
SUMP PUMP:	NO	SEWER:	CITY
LP TANK:	NA	HEATING:	FA/NG (NEW 2007)
GARAGE:	12' X 18' DET	ELEC.:	CITY
BASEMENT:	FULL	220:	NO
B. FLOOR:	CONCRETE	FLOOR DRAIN:	YS
DRIVEWAY:	CONCRETE	FLOOD ZONE:	NO
FOUNDATION:	STONE		

FLOOR PLAN	MAIN LEVEL	UPPER LEVER	LOWER LEVEL
BREEZEWAY			
LIVING ROOM	X		
DEN/OTHER			
REC. ROOM			
DINING ROOM	X		
DINING AREA	X		
KITCHEN	X		
BATH	STOOL	X	
BEDROOM/S	X	XXX	
LAUNDRY	X		

APPLIANCES / ITEMS TO STAY:	NONE
ITEMS THAT DO NOT STAY:	SHED

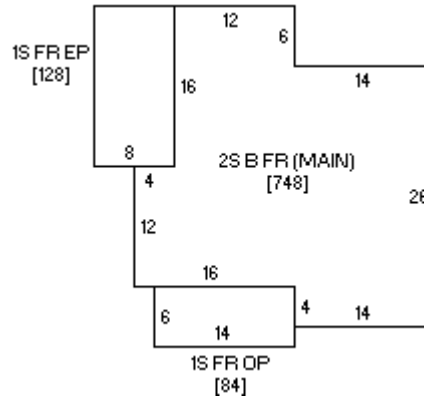

SELLER IS SELLING "AS IS"

Owner: Joseph Thronson & Teske Property
Legal: Lot 1 & 2, Block 23 Railroad Addition

\$28,500.00

112 North Linn Ave.

New Hampton

FIRST Choice REALTY



402 E. Grove
P.O. Box 62
Lawler, Iowa 52154

LISTING # 354 "P"

This information has been carefully compiled by the staff of First Choice Realty from sources deemed to be reliable but is not guaranteed by First Choice Realty.